

Grumman AA5 Front Seat Pan Access Hole Modification for Accessing Seat Attach Bolts

Top View of Seat Pan

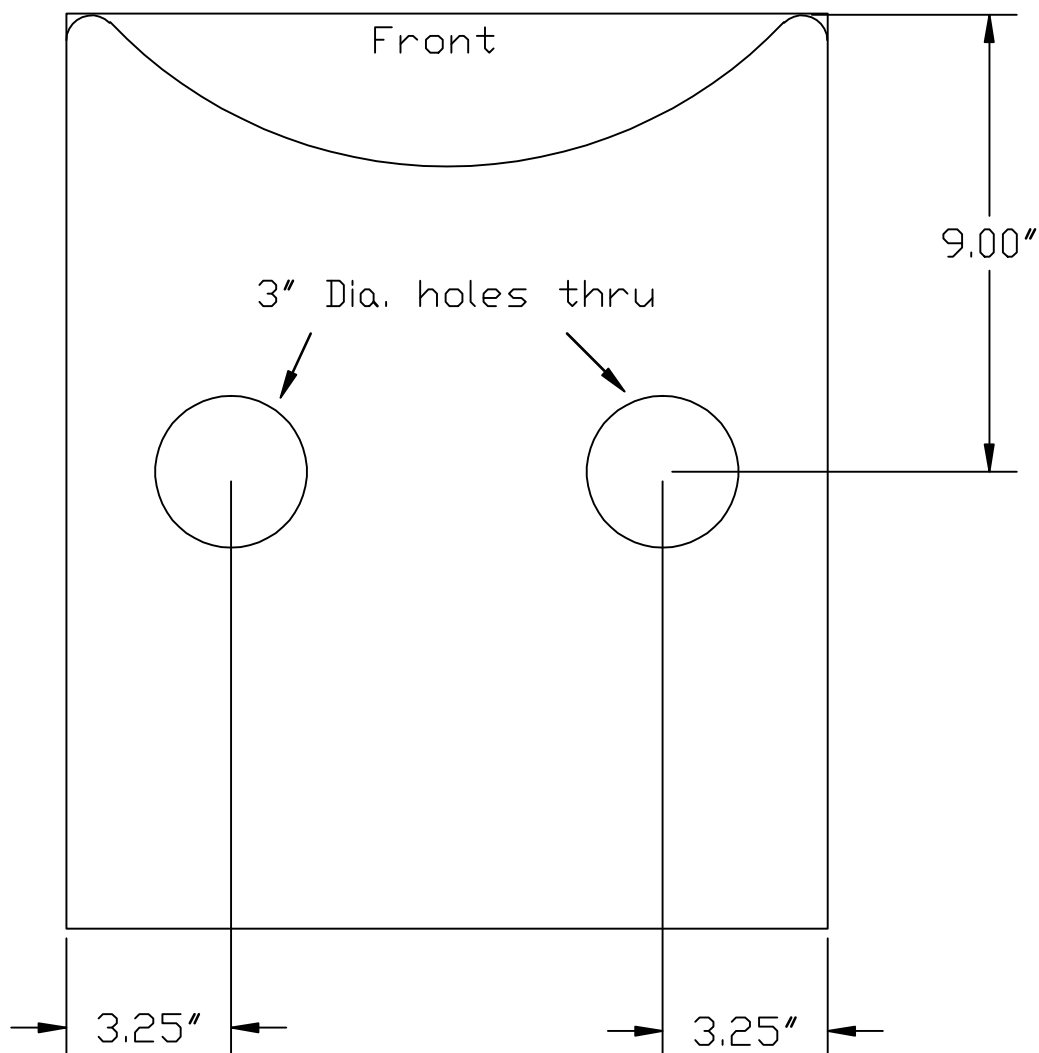

Procedure and Warning Notes:

Remove seat pan from aircraft before cutting holes.

Check for clearance below hole locations to prevent damage to other seat parts. Use a wood block as a buffer between bottom of seat pans and other parts.

Be sure to secure seats to prevent movement when drilling holes

Use a 3 inch hole saw turning at low speed to cut access holes in seat pan.